

235 SERIES

Horizontal Hold Down Clamps | Product Overview

Features:

- Low profile
- Available with DESTACO® Toggle Lock Plus
- Available in stainless steel

Applications:

- Assembly
- Checking fixtures
- Welding
- Closures
- Woodworking

Also Available:

See page MC-ACC-1 for accessories
Accommodates M10 or 3/8" spindle accessory

Covered under one or more U.S./International Patents

235-U
Flanged Base
U-Bar



235-USS
Flanged Base, U-Bar,
Stainless Steel



235-UR
Flanged Base, U-Bar
with DESTACO®
Toggle Lock
Plus



235-UB ⓘ
Straight Base
U-Bar



Technical Information

Model	Max. Holding Capacity	Clamp Bar Opening (+10°)	Handle Opening (+10°)	Weight	Accessories (Supplied)	
					Spindle Assembly	Flanged Washers
235-U	3340 N [750 lbf]	92°	70°	0,67kg [1.47lb]	240208-M	235106
235-USS	3780 N [850 lbf]				237943-M	235906
235-UR	3340 N [750 lbf]	92°	70°	0,74kg [1.64lb]	240208-M	235106
235-UB ⓘ				0,67kg [1.47lb]		

ⓘ This item is available upon request

Holding Capacities

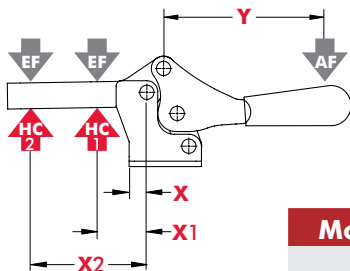

Model	X	X1	X2	Y	‡HC1	‡HC2	‡EF(X1):AF	‡EF(X2):AF
U					[750lbf.] 3340N	[300lbf.] 1330N	9:1	5:1
USS	[0.25] 6,4	[1.75] 44,5	[4.13] 105	[5.75] 146	[850lbf.] 3780N	[360lbf.] 1600N		
UR/UB					[750lbf.] 3340N	[300lbf.] 1330N		

Dimensions shown "mm [inch]" ‡ HC = Holding Capacity, EF = Exerting Force, AF = Applied Force
See page MC-TEC-4 for additional information.

235-U Flanged Base U-Bar

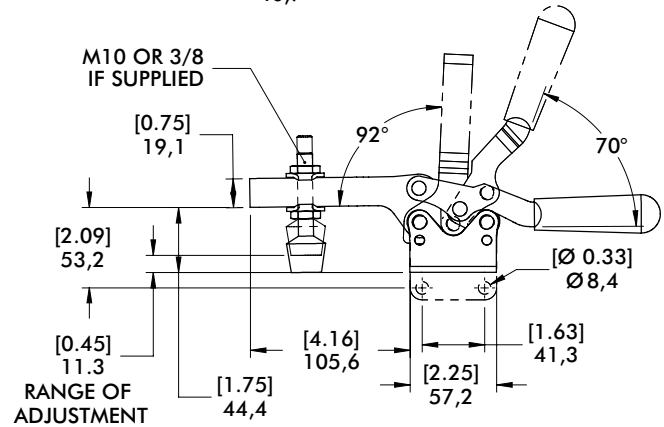
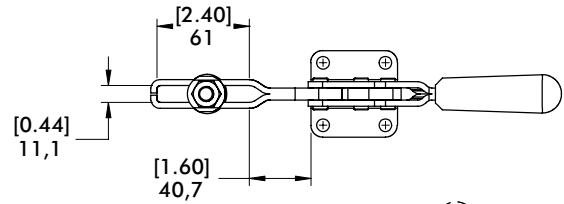
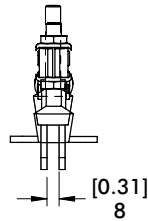

Dimensions | -UR

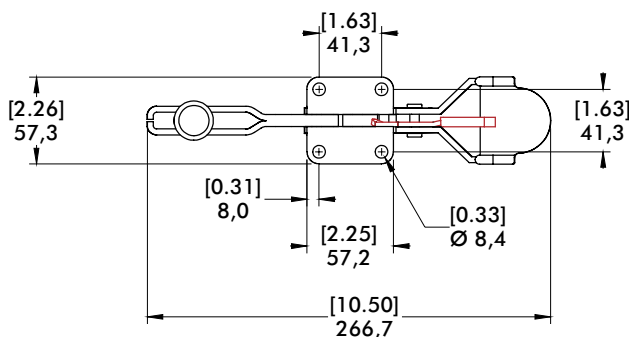
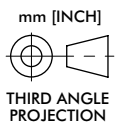
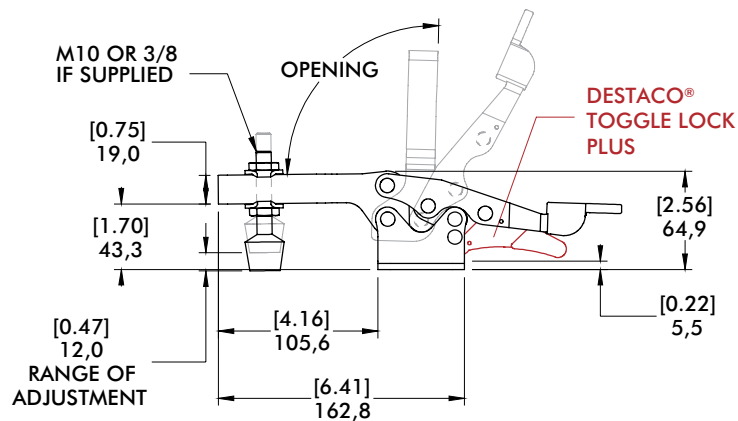
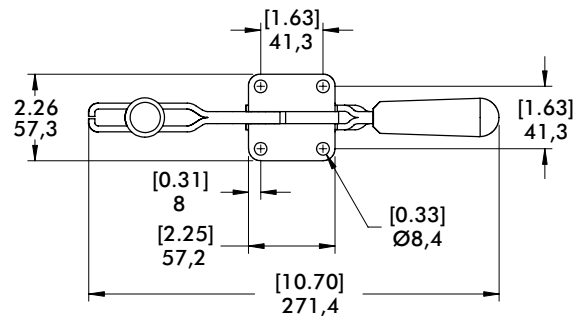
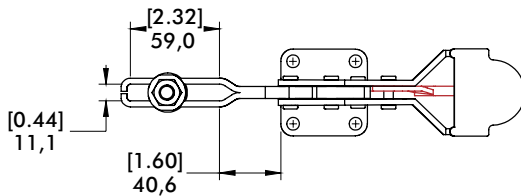

235-UR Flanged Base, U-Bar with DESTACO® Toggle Lock Plus

